

Mars Surface Tunnel Element Concept

Michelle A. Rucker
 NASA Johnson Space Center
 2101 Nasa Parkway
 Houston, TX 77058
 281-244-5569
 michelle.a.rucker@nasa.gov

Sharon Jefferies
 NASA Langley Research Center
 1 Langley Boulevard
 Hampton, VA 23681
 757-864-4248
 Sharon.a.jefferies@nasa.gov

A. Scott Howe
 NASA Jet Propulsion Laboratory
 4800 Oak Grove Drive
 Pasadena, CA 91109
 818-354-4492
 Scott.Howe@jpl.nasa.gov

Robert Howard
 NASA Johnson Space Center
 2101 Nasa Parkway
 Houston, TX 77058
 281-244-1007
 robert.l.howard@nasa.gov

Natalie Mary
 Booz Allen and Hamilton
 2101 Nasa Parkway
 Houston, TX 77058
 281-483-0693
 natalie.a.mary@nasa.gov

Judith Watson
 NASA Langley Research Center
 1 Langley Boulevard
 Hampton, VA 23666
 757-864-3116
 judith.j.watson@nasa.gov

Ruthan Lewis
 NASA Goddard Space Flight Center
 8800 Greenbelt Road
 Greenbelt, MD 20771
 301-286-0818
 ruthan.lewis@nasa.gov

Abstract—When the first human visitors on Mars prepare to return to Earth, they will have to comply with stringent planetary protection requirements. Apollo Program experience warns that opening an EVA hatch directly to the surface will bring dust into the ascent vehicle. To prevent inadvertent return of potential Martian contaminants to Earth, careful consideration must be given to the way in which crew ingress their Mars Ascent Vehicle (MAV).

For architectures involving more than one surface element—such as an ascent vehicle and a pressurized rover or surface habitat—a retractable tunnel that eliminates extravehicular activity (EVA) ingress is an attractive solution. Beyond addressing the immediate MAV access issue, a reusable tunnel may be useful for other surface applications, such as rover to habitat transfer, once its primary mission is complete.

A National Aeronautics and Space Administration (NASA) team is studying the optimal balance between surface tunnel functionality, mass, and stowed volume as part of the Evolvable Mars Campaign (EMC). The study team began by identifying the minimum set of functional requirements needed for the tunnel to perform its primary mission, as this would presumably be the simplest design, with the lowest mass and volume. This Minimum Functional Tunnel then becomes a baseline against which various tunnel design concepts and potential alternatives can be traded, and aids in assessing the mass penalty of increased functionality.

Preliminary analysis indicates that the mass of a single-mission tunnel is about 237 kg, not including mass growth allowance.

TABLE OF CONTENTS

1. INTRODUCTION.....	1
2. MINIMUM FUNCTIONAL TUNNEL.....	2
3. TUNNEL DESIGN CONSIDERATIONS.....	3
4. MINIMUM FUNCTIONAL TUNNEL CONCEPT.....	5

5. ALTERNATE USES	8
6. FORWARD WORK.....	9
8. CONCLUSIONS	10
ACKNOWLEDGEMENTS	10
REFERENCES	10
BIOGRAPHY	11

1. INTRODUCTION

The National Aeronautics and Space Administration’s Evolvable Mars Campaign (EMC) [1] is an ongoing series of architectural trade analyses to define the capabilities and elements needed for a sustainable human presence on the surface of Mars.

Crewed Mars Surface Mission

As currently envisioned in the EMC framework, a crewed surface mission begins with delivery of the crew’s return vehicle, called the Mars Ascent Vehicle (MAV, Figure 1). To save landed mass, the MAV lands on Mars with empty liquid oxygen propellant tanks more than a year before the crew arrives and extracts oxygen from the Martian atmosphere. When the MAV’s propellant tanks are confirmed full, the crew lands and spends up to 500 sols working on Mars. Additional surface architecture elements include at least one pressurized rover (Figure 2) and surface habitat. Current pressurized rover concepts include two suitports (Figure 3) that allow EVA suited crew to enter the rover by forming a pressure seal between the back of their suits and the rover’s suit ports [2]. This allows them to leave their dusty suits outside the rover. At the end of their mission, the crew transfer into the MAV and depart.



Figure 1. Mars Ascent Vehicle Conceptual Design



Figure 2. Mars Pressurized Rover Conceptual Design



Figure 3. Suit Port Concept

Why Do We Need A Tunnel?

If the MAV is never used for habitation, it will remain unused until the final sol of the surface mission. This keeps

the MAV’s crew cabin free from surface dust, and serves an important role in providing planetary protection back to Earth [3]. But how do we keep the crew from tracking Martian dust into the MAV? If the crew were to simply walk from their surface habitat to the MAV, open the hatch and climb aboard, the MAV cabin would be directly exposed to the surface, plus the crew would ascend wearing dusty Extravehicular Activity (EVA) space suits. To meet planetary protection protocols, the architecture has to do two things: 1. Allow crew to ingress the MAV without exposing the cabin directly to the surface and, 2. Facilitate crew ingress to the MAV wearing clean Intra-vehicular activity (IVA) clothing or pressure suits that have never been outside a pressure cabin. Planetary protection aside, there is another compelling reason to push EVA suit don/doff and EVA operations to an element that remains on the surface: it can reduce the ascent propellant load by hundreds of kilograms. Preliminary analysis indicates the MAV will require at least seven kilograms (kg) of propellant to launch each kilogram of cabin mass [4], so a MAV carrying four IVA-suited crew requires about 560 kg less propellant than if they were wearing the heavier EVA suits (even without the large life support system backpack). What’s more, the “elbow room” needed to remove and stow EVA suits—which are each about the size of a crew member—requires a larger MAV crew cabin and that in turn would require even more propellant to launch.

Although there are numerous alternatives, a retractable, pressurized tunnel from a pressurized rover may be the simplest, lowest mass option because the tunnel and EVA suits can be left behind on the surface.

Study Objectives

The primary objectives of this study were to define surface tunnel functional requirements and minimum estimated mass for the purpose of trading various MAV ingress/egress options. A secondary objective was to identify potential alternative uses for a surface tunnel element, once its primary mission is complete.

Study Approach

The study team began by identifying the minimum set of functional requirements needed for the tunnel to perform its primary mission, as this would presumably be the simplest design, with the lowest mass and volume. This Minimum Functional Tunnel then becomes a baseline against which various tunnel design concepts and potential alternatives can be traded, and aids in assessing the mass penalty of increased functionality.

2. MINIMUM FUNCTIONAL TUNNEL

The “Minimum Functional Tunnel” is a conceptual design that performs a single function: getting IVA-suited crew from a pressurized rover into the MAV without having to step outside into the Mars environment. If this minimum functional tunnel mass and volume fits within available

lander stowage allocations, then additional “bells and whistles” that might allow the tunnel to perform other jobs may be considered. If not, then the minimum functional tunnel mass and volume will be traded against alternative approaches.

Minimum Functional Requirements

At a minimum, the surface tunnel must:

- R1. Provide a controlled environment between the MAV and pressurized rover, isolated from the Martian environment
- R2. Provide an environmental seal around ingress/egress hatches on both the MAV and pressurized rover.
- R3. Provide sufficient internal volume for passage of up to four crew members (not necessarily all at the same time) wearing IVA suits.
- R4. Provide sufficient crew interface devices (such as handrails) to facilitate crew translation.
- R5. Provide a means of aligning with the rover.
- R6. Provide a means for detaching from the MAV.

The lander descent stage serves as the MAV’s launch pad structure, so the MAV must remain elevated on top of the descent stage after landing, as shown in Figure 4. Assuming current design concepts, this vertical difference places the MAV hatch approximately 2.2 m higher than the rover hatch (assuming both are on level terrain), which drives one additional tunnel function:

- R7. Accommodate a relative elevation difference between the MAV and rover.

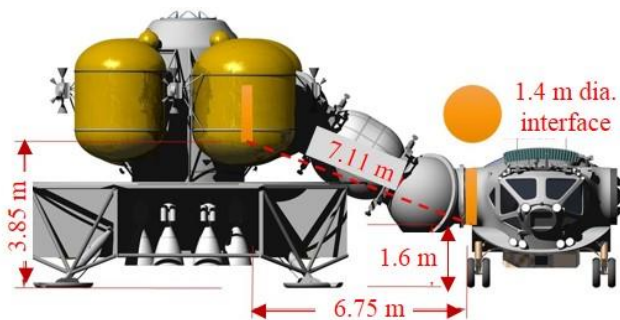

Figure 4. MAV Elevation Relative to Rover

It should be noted that this elevation mismatch applies not only for rover-to-MAV translation, but potentially also to rover-to-habitat translation if the surface habitat remains on top of its lander. If the tunnel is to be repurposed for Habitat access, the same requirement may apply.

General Concept of Operations

The following general concept of operations was developed to facilitate minimum functional tunnel definition:

The surface tunnel is attached at the MAV’s ingress/egress hatch on Earth, and remains attached through Earth launch, transit, Mars entry, descent, and landing. The tunnel is unused until the crew prepare for departure. Before crew departure, a two-person MAV check-out crew transfers from their surface habitat to the pressurized rover, and drives to the MAV. The check-out crew deploys the tunnel and attaches it to the pressurized rover’s ingress/egress hatch, and verifies the tunnel is environmentally sealed from surface dust. Wearing clean IVA clothing, the check-out crew translate from the pressurized rover to the MAV to stow return cargo and perform MAV pre-flight inspections. Upon completion of MAV preparations, the check-out crew retreats back through the tunnel to their pressurized rover, closing the tunnel hatch before detaching and driving back to the habitat. After securing the surface habitat, all four crew transfer from their surface habitat to the pressurized rover, drive to the MAV, and re-dock with the tunnel. After translating from the pressurized rover to the MAV in their clean IVA suits, the crew detaches the tunnel from the MAV and departs Mars.

3. TUNNEL DESIGN CONSIDERATIONS

There are numerous implementation strategies to meet the seven functional requirements identified above, but the following design considerations should be addressed.

R1. Controlled Environment

To meet planetary protection requirements, the surface tunnel must allow crew to translate between a pressurized rover and the MAV without being exposed to the Martian surface, requiring a passageway between the two vehicles. There are numerous implementation options to do this, ranging from a fixed, rigid structure to inflatables or convoluted retractable devices.

The tunnel could be designed for shirt-sleeve translation, but at some point the crew must don IVA suits for ascent and there will be more elbow room to do this in the rover than in the MAV. If the crew are wearing IVA suits, the tunnel does not necessarily have to be pressurized, though there are several reasons to do so. First and foremost, positive pressure inside the tunnel reduces the chance that Martian dust will leak in. Second, if the tunnel is pressurized below suit minimum pressure, then the crew will have to translate wearing gloves and helmets, in an inflated suit—which is much more difficult than wearing an unpressurized suit and carrying helmet and gloves. Finally, a pressurized inflatable tunnel opens up the design space to include inflatables. There are at least five options for pressurizing the tunnel: a self-contained system (though that adds mass and complexity to the tunnel), pressurize from the MAV (though that adds mass to the MAV), pressurize from the lander descent stage, pressurize from the rover, or some combination of these options (for example, equalize pressure between the MAV and rover). Note that current MAV and rover concepts both operate at 56.5 kilo Pascal

(kPa) pressure. If the tunnel is pressurized, the integrated design must take into account pressurization loads on the MAV and rover.

R2. Hatches

Regardless of what internal pressure the tunnel operates at, it must provide an environmental seal around both the MAV and rover hatches. Current design concepts specify the same hatch on both vehicles, measuring 1 meter (m) x 1 m square. This allows both ends of the tunnel to be identical and sets the minimum tunnel diameter.

The MAV end of the tunnel arrives pre-connected, but the rover end of the tunnel would be exposed to the surface without a dust cover at a minimum. Depending on how the tunnel is operated, it may be prudent to include a pressure hatch on the rover end to avoid loss of pressure between uses. In that case, the design must be coordinated with the rover team to mitigate hatch swing interference between the two elements.

R3. Internal Volume

Tunnel volume is a function of tunnel cross-sectional area and length. To minimize structural mass and oxygen consumables (if the tunnel is pressurized), the tunnel volume should be as small as possible. At a minimum, the cross section must be large enough for a single IVA-suited crew member to slide through in a horizontal position.

Another consideration is whether cargo or equipment will be transferred through the tunnel. The current EMC baseline specifies 250 kg of cargo returning with the crew. For the purpose of this exercise, the study team assumed that the largest piece of equipment passing through the tunnel would be crew seats, each measuring approximately 0.88 m deep x 1.5 m long x 0.7 m wide.

R4. Crew Interfaces

In microgravity, handrails are sufficient for crew translation through a long tunnel (Figure 5), but in Mars gravity the crew will be in contact with the bottom of the tunnel. Crew interfaces will depend on several factors, including whether the tunnel is sized for sliding, crawling, or walking, whether the structure is rigid or flexible, whether the tunnel is horizontal or at an incline, and whether the tunnel is a smooth bore or a convoluted structure. An internal ladder may be needed if the tunnel is at a steep incline. For sliding, options include using a winch to pull each crew member through the tunnel or mounting a pair of rails inside the tunnel attached to a sliding translation seat. Regardless of the translation method, crew interfaces will add some mass to the tunnel assembly and must be accounted for.

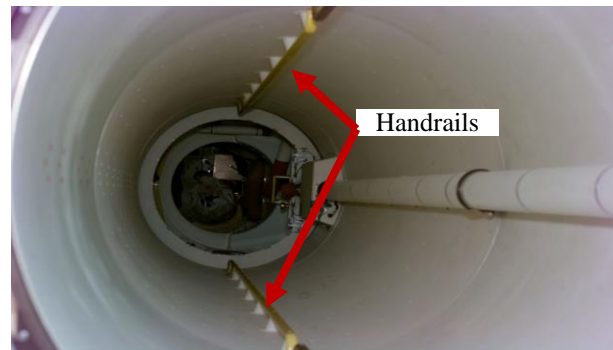

Figure 5. Tunnel Crew Translation Aids

R5. Rover Hatch Alignment

Current rover concepts offer approximately +/- 2.5 cm of fine adjustment, so additional alignment capability is likely needed. This may be accomplished by provisions inherent in the tunnel design (potentially adds mass), or through external means, such as a robotic arm mounted on the rover or lander (more complicated, but if the rover or lander already carry a robotic arm, there is no additional mass penalty).

R6. Docking

Regardless of how the tunnel is manipulated into position, it must provide a means for one end to attach to the rover and later detach the other end from the MAV. A pyrotechnic device could be used to sever the connection, though this may preclude re-use of the tunnel after the MAV departs, and could risk damaging either the MAV or rover. Alternatives to a pyrotechnic solution include a simple manual latching system or a complex active docking system. On the MAV side, the crew is available to release latches from inside the MAV, but rover-side tunnel separation would have to be remotely actuated. Because the rover may dock two or three times during MAV preflight checkouts, the rover end of the tunnel will require a reusable solution.

R7. MAV and Rover Relative Positions

As noted above, the relative elevation difference between the MAV and rover hatches is approximately 2.6 m on level ground. This alone drives the tunnel to be several meters long.

To balance the lander, the large, heavy MAV is positioned in the center of an approximately 9 m diameter lander deck. If the rover parks as close to the lander as possible, the sharp tunnel angle between the two will clip the edge of the lander deck as shown in Figure 6. Simply removing this portion of lander deck may solve the issue, but because the descent engines and propellant tanks are mounted under the deck, this may not be possible.

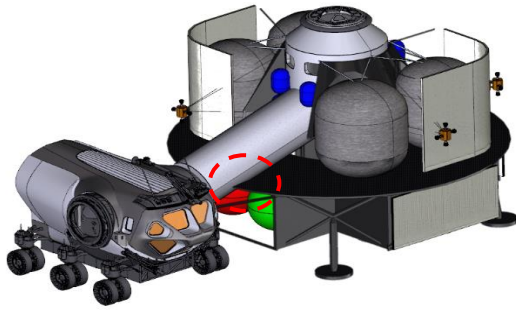

Figure 6. Lander Deck/Tunnel Interference

A second option is to park the rover farther away from the lander, giving the tunnel a shallower angle that allows it to clear the deck. However, this makes the tunnel longer and poses a new set of challenges related to tunnel mass, stowage volume, and ease of handling.

A third option is to raise the rover's elevation, but this would require significant internal rover chassis adjustability or external means such as modifying the terrain, or employing a ramp, jack or other equipment—all adding mass, complexity, and risk.

A fourth option is to employ a segmented tunnel that can articulate around the lander deck obstacle, such as shown in Figure 7, though this may also add considerable mass.

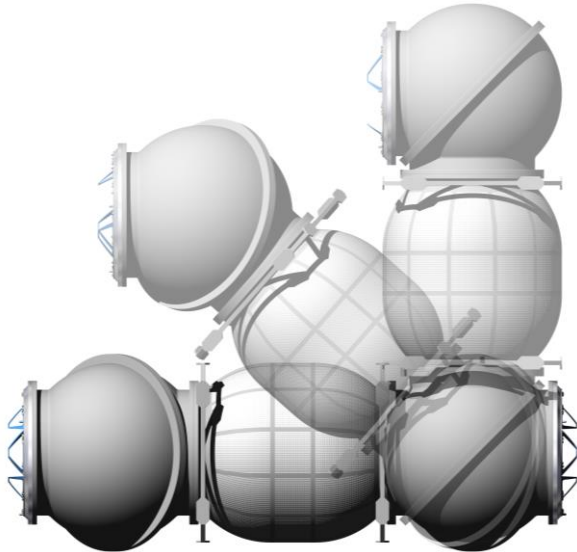

Figure 7. Articulating Tunnel

4. MINIMUM FUNCTIONAL TUNNEL CONCEPT

Assumptions

To focus the minimum functional tunnel concept, the study team made the following assumptions based on preliminary MAV and rover concepts, known operational constraints, and many of the design considerations outlined above:

- A1. The tunnel arrives with one end pre-attached to the MAV.
- A2. Tunnel is used for both crew and equipment translation.
- A3. Tunnel must be large enough to allow passage of equipment up to 0.88 m deep x 1.5 m long x 0.7 m wide.
- A4. Tunnel must accommodate crew physical stature and mass per Orion Multipurpose Crew Vehicle (MPCV) requirements [5].
- A5. To minimize mass, services to the tunnel (power, thermal control, ventilation, etc.) are not provided by the tunnel element itself.
- A6. The tunnel is not used before the crew arrives.
- A7. The tunnel must accommodate 1 m x 1 m square pressure hatches on either end.
- A8. The tunnel must operate at positive pressure relative to the Mars surface, to prevent contaminants (dust, toxic chemicals, etc.) from the Martian environment leaking into the tunnel.
- A9. If pressurized for IVA translation, the tunnel must operate at 56.5 kPa differential pressure, and materials must be compatible with an internal atmospheric oxygen concentration of 34%.
- A10. Tunnel must accommodate an incapacitated crew member. Note that transfer of an incapacitated crewmember could be accomplished using a winch without a second crew member inside the tunnel.
- A11. Tunnel must perform at least three rover mate/demate cycles, to accommodate pre-launch MAV preparation as well as crew departure.
- A12. Tunnel must meet a minimum 10 year life cycle from Earth launch to disposal, with at least four years of that life cycle on the Mars surface.

Conceptual Design

Figure 8 outlines the trade tree of design options to meet each functional requirement. The study team settled on a multi-layer inflatable tunnel body, with one end pre-attached to the MAV and a pressure hatch on the other end. The 7.11 m long, 1.4 m diameter tunnel would be compressed like an accordion, and stowed against the MAV during descent and landing. 56.5 kPa inflation pressure would be provided by the lander descent stage, using stored gasses, residual oxygen propellant, oxygen manufactured from in situ resources, or some combination of these. The tunnel would remain stowed until the crew began MAV launch preparations a few days before departing from Mars.

Drawing from previous work on the Transhab project [6] [7] [8] combined with new materials, the study team selected a fabric tunnel body consisting of thermal insulation, impact resistant layers, a restraint cloth layer, redundant internal bladders, an internal scuff layer, and 10 external restraint straps (Figure 9). Metal frames at either end provide structure for sealing to the MAV and rover.

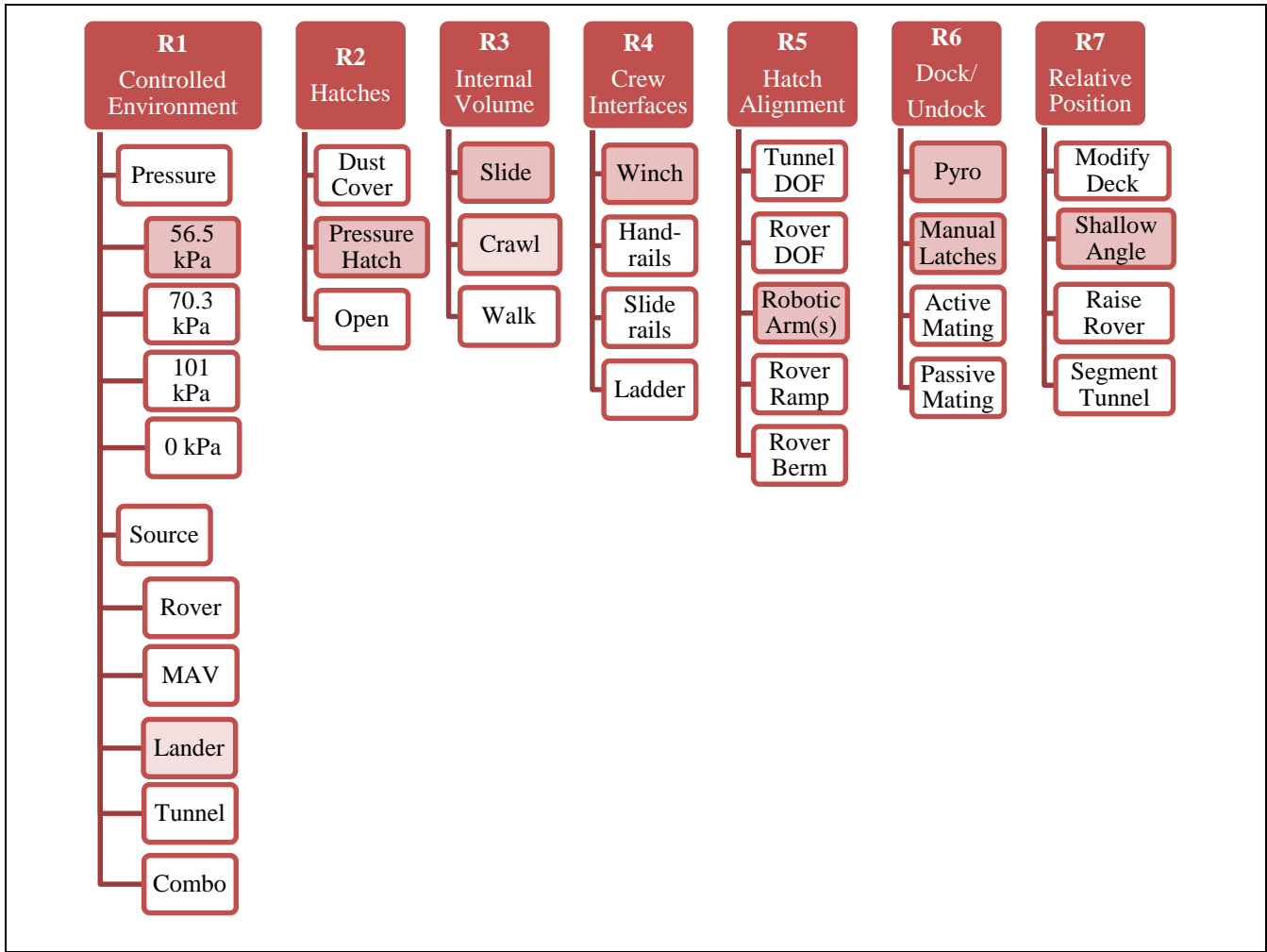

Figure 8. Options Trade Tree



Figure 9. Rover-to-MAV Surface Tunnel Concept

Tunnel deployment and docking could be autonomous or remotely operated, but EVA crew participation is likely to offer mass and power savings.

After manually releasing tunnel launch/landing restraints, the crew activates the inflation system to slowly inflate the tunnel. Once fully pressurized, the tunnel will be fairly rigid but partial inflation allows the tunnel to be more easily guided into place. As the rover-end of the tunnel reaches the edge of the lander deck, a surface support structure automatically deploys, much like the legs of a stretcher drop down as paramedics pull it from an ambulance. This will help support the rover-end of the tunnel when the rover is not present, and keep the hatch mechanism from contacting the Mars surface during deployment.

With the tunnel partially inflated the crew positions the rover near the tunnel pressure hatch and uses the rover’s robotic arm to grapple a fixture on the outside of the tunnel and guide it into position. For the purpose of this exercise, the Study team assumed a tunnel grappling fixture similar to the heritage Flight Releasable Grapple Fixture (Figure 10)

that was used on the Space Shuttle and International Space Station programs.

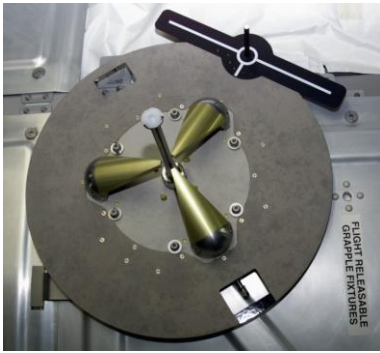

Figure 10. Flight Releasable Grapple Fixture

After the tunnel is latched to the rover, the crew inflates it to full pressure and manually adjusts the tunnel's ground support structure as needed. With the tunnel now secured between the MAV and rover, the MAV preparation crew changes into their clean IVA suits inside the rover, opens the rover and tunnel pressure hatches, and crawls through the tunnel up into the MAV (Figure 11). Standard handrails at each end of the tunnel help with hatch ingress. A maintenance kit, consisting of fabric patches and tools would be available for repairs.

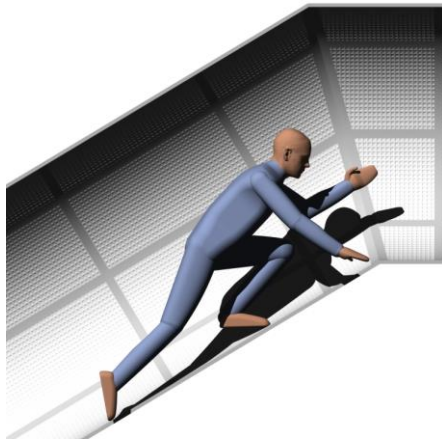

Figure 11. MAV Ingress via Pressurized Tunnel

A MAV-mounted winch can be used to pull cargo up into the MAV for stowage. For the purpose of this exercise, the Study team assumed the winch would be similar to the heritage Space Shuttle EVA winch (Figure 12). Originally used to close the Shuttle's payload bay doors, the manually operated Shuttle winch carries 7.3 m of 9.5 mm Kevlar rope, and is rated for 272 kg load.

The winch could be motorized, or manually operated to reduce mass and power. Once the MAV preparation crew completes vehicle checkouts, they would slide or crawl down the tunnel into the rover, close the tunnel and rover pressure hatches, undock from the tunnel and return to the habitat. On departure day, the entire IVA-suited crew

would return in the rover. After docking to the tunnel, they would open the pressure hatches and crawl up into the MAV. The winch could be used to hoist an incapacitated crew member through the tunnel. The last crew member to leave the rover would close both the rover and tunnel pressure hatches. Because of its placement near the MAV hatch, the winch might be useful later in the MAV's mission for contingency operations. However, the winch could be removed and placed into the tunnel before closing the MAV hatch to minimize MAV mass impacts.

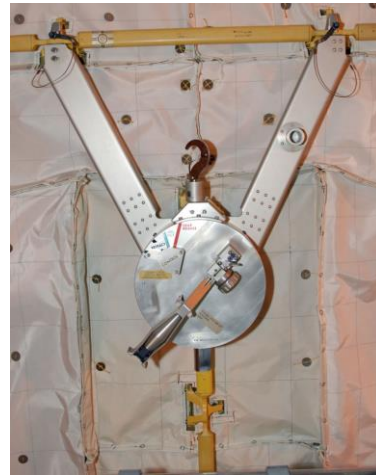

Figure 12. Space Shuttle Winch

After closing the MAV hatch, the tunnel would be manually disconnected from the MAV, and the rover commanded to pull the tunnel far enough from the MAV that it poses no hazard to launch. The rover would then undock from the tunnel and autonomously return to the habitat.

Estimated Mass

In lieu of a detailed design, a minimum functional tunnel mass of 236.7 kg was developed from a combination of heritage hardware specifications and new hardware estimates. A summary of individual component masses is shown in Table 1. Note that this mass estimate does not include mass growth allowance, nor does it include the tunnel inflation system. Depending on lander design, some portions of the inflation system may already be available on the lander.

Table 1. Estimated Tunnel Mass

Component	Mass (kg)
MAV-Side Latches	17.3
MAV-Side End Frame	28.3
MAV-Side Winch	9.5
Winch Motor	10.0
Tunnel Body	52.1
Tunnel Straps	2.7
Grappling Fixture	9.1
Rover-Side Hatch Frame	28.3

Ground Support Structure	30.0
Rover-Side Pressure Hatch	30.0
Rover Mating Mechanism	13.0
Handrails (2 each, 30.5 cm long)	1.4
Maintenance Kit	5.0
Total	236.7

5. ALTERNATE USES

After investing in a surface tunnel, re-using it will be more cost-effective than discarding the tunnel and sending a new one with the next MAV. The most obvious opportunity is to manifest one tunnel and re-use it for subsequent MAV missions, though this adds new functional requirements to the design: the tunnel would have to be mobile, and capable of more mate-demate and usage cycles. Mobility does not necessarily have to be provided by the tunnel itself but the tunnel may need to be deflated and compressed in order to be relocated.

The study team also explored applications beyond the primary rover-to-MAV case.

Habitat-to-Rover Transfer

Notionally, EMC operational concepts envision a rover docking to the surface habitat for crew transfers. As noted above, if the habitat remains on top of a lander, vertical misalignment between the two vehicles may lend itself to a transfer tunnel of some sort, similar to the MAV-to-rover case. Re-purposing the MAV tunnel for this application—or manifesting a dedicated tunnel for Habitat usage—would add two important functional requirements to a common design: the tunnel would have to accommodate larger hatches and higher internal pressures, which may in turn increase mass.

Current surface habitat concepts envision a large 1 x 1.5 m hatch to accommodate frequent ingress/egress. This would require one end of the tunnel to be larger than the other end, increasing tunnel mass and handling complexity. Current pressurized rover and MAV concepts are matched for nominal operation at 56.5 kPa cabin pressure, and can both tolerate cabin depressurization, whereas current surface habitat concepts operate at 101 kPa, with nominal depressurization more problematic. Therefore, the surface tunnel would also have to meet higher differential pressure requirements (which would slightly increase its mass) if re-purposed for rover-to-Habitat operation.

Habitat-to-Habitat Transfer

One architecture trade being studied by the EMC is a single, monolithic surface habitat versus multiple modular habitats. A pressurized tunnel would allow shirt-sleeve translation between multiple modules. Although a single monolithic habitat could remain on top of its lander descent stage, modular habitats would likely be offloaded and positioned

near each other. This would eliminate the lander deck interference issue noted in the nominal usage case, and could allow for much shorter tunnels between habitat modules. For re-use in this application it would make sense to employ a segmented rover-to-MAV tunnel assembly that could be broken into shorter sections for habitat-to-habitat use. However, this would likely add mass, and each tunnel segment joint would become a potential pressure or dust leak path. Also note that in this application, both ends of the tunnel would have to accommodate the larger habitat hatches. Although crawling or sliding through a small diameter tunnel is acceptable for the infrequent rover-to-MAV usage, frequent (many times per sol) translations between habitat modules would be more comfortable if the tunnel diameter could accommodate upright walking, making the tunnel oversized for its primary rover-to-MAV mission. What's more, the tunnel would have to be maintained at the habitat's higher pressure for much longer periods of time, likely resulting in more stringent reliability requirements.

Habitat-to-Logistics Module Transfer

EMC architectures envision pressurized logistics modules (Figure 13) to deliver crew provisions, spare parts, and science equipment. Ideally, these containers would be attached directly to a surface habitat port. If direct connection is not possible, a pressurized tunnel might be useful. A tunnel used for this application would require the same functionality noted above for the habitat-to-habitat or habitat-to-rover cases.

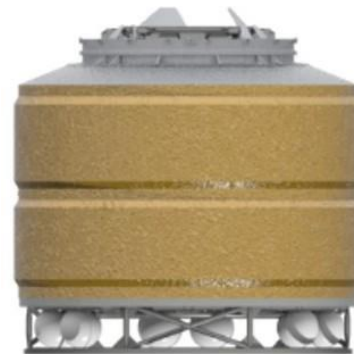

Figure 13. Logistics Module

Rover-to-Rover Transfer

Another potential tunnel application is to join two pressurized rovers together. As with the modular habitat-to-habitat case, both rovers would be at the same elevation allowing for a relatively short tunnel. However, unlike habitat applications, a rover-to-rover tunnel only needs the smaller MAV-sized hatches on both ends and could operate at 56.5 kPa or lower internal pressure. The problem is that this application would likely only be used during rover excursions far from the lander base—which means that either the tunnel must have an ability to deploy/retract itself, or the rovers must carry a tunnel handling mechanism.

Either way, this application adds cargo mass to the rovers which likely reduces their excursion distance per sol.

Habitat- or Rover-to-Laboratory

To preserve the integrity of collected Martian samples and facilitate planetary protection, the architecture may include a science laboratory that is completely separate from the habitat. If the laboratory is pressurized then a habitat- or rover-to-laboratory tunnel would require similar functionality to the habitat-to-habitat or rover-to-habitat cases previously discussed. But unlike the other elements discussed here, the science laboratory may not actually be pressurized (in order to work with samples under Martian ambient conditions). What's more, scientists may prefer robotic sample handling rather than shirt-sleeve or even EVA-suited crew handling. In this case, there is no need for a tunnel.

Storage

Another potential use for a tunnel element is to provide additional storage, as part of another element or stand-alone. As a stand-alone element a discarded tunnel could be repurposed as a waste disposal container. Attached to a habitat, a tunnel could serve as an extra storage compartment, though this would require a dedicated habitat hatch.

Contingency Uses

The study team explored two potential contingency uses for a surface tunnel when attached to a habitat: as an emergency airlock, or as an emergency safe haven. To use a surface tunnel for either of these contingency cases adds two significant new functions to the design: the tunnel itself must provide services (particularly oxygen and power) since there is a presumption that the mating vehicle is disabled, and the tunnel must be large enough to accommodate the larger, bulkier EVA suits. The study team quickly concluded that a surface tunnel is not the optimum element to address these contingencies.

6. FORWARD WORK

Tunnel Trades

Given the minimum functional tunnel concept—which is presumably the simplest, lowest mass and volume design—the study team will be able to trade various design options across the expanded list of operational concepts and alternative uses.

Tunnel Alternatives

A minimum functional tunnel may be an adequate solution for a one-mission problem, but may not be optimum over a multi-mission surface campaign. In future studies, the following tunnel alternatives will be traded against tunnel concepts for mass, operational complexity, and risk.

EVA Hatch—EVA hatches have the benefit of relatively low mass and high Technology Readiness Level (TRL). But an EVA hatch would require MAV depressurization for every ingress/egress, and the MAV would have to be big enough for all crew members to don/doff their EVA suits together. Altair project mockup testing [9] found that even three EVA suited crew could stand together in a relatively small 1.8 m diameter cabin. However, getting into and out of their EVA suits was hampered by a rear-entry suit design that requires the PLSS hatch to swing open laterally for suit doffing (Figure 14). In practice, this either forces the cabin diameter to grow to accommodate PLSS hatch swing, or it will drive a fundamental design change to the EVA life support system. These issues aside, the biggest drawback to an EVA hatch is that it will be virtually impossible to keep dust out of the MAV. Apollo experience [10] warns that opening an EVA hatch directly to the surface will bring dust into the ascent vehicle, which drives MAV cabin design and equipment mass to prevent Martian dust from migrating back into the transit vehicle and eventually to Earth.



Figure 14. EVA PLSS Interference

Airlock—An airlock module provides better dust mitigation than an EVA hatch, but would still place dusty EVA suits in close proximity to an open MAV hatch. As dust settles to the Airlock floor, some means to keep IVA-suited crew from tracking the dust into the MAV would also be required. An interesting option might be an inflatable airlock (Figure 15).

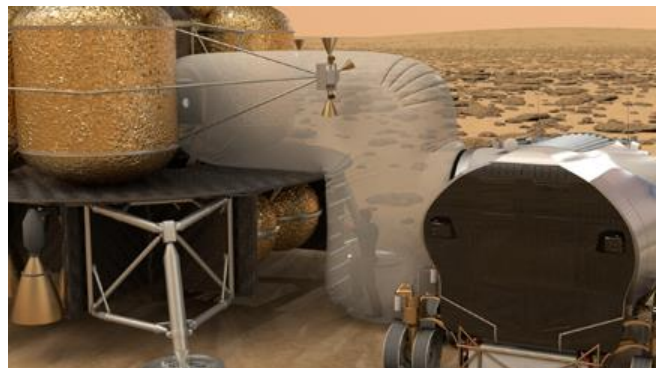

Figure 15. Inflatable Airlock Concept

Suitport—As noted above, suitports (Figure 3) offer the promise of dust mitigation by keeping dusty suits entirely outside the pressure cabin, but current protocol still requires an EVA hatch to get the suits outside for the first EVA, and back inside after the final EVA. This is primarily because current designs do not provide enough structural support to protect the suits from ascent/descent loads or potential thruster plume impingement. Concepts to address these problems have been proposed, but add even more mass to each suitport (which are already more than 100 kg each). Even if the structural problem is resolved, an EVA hatch is still required for an incapacitated crew member contingency, since it may not be possible to pull an unconscious person up through the suit’s rear-entry hatch to safety.

Preliminary analysis indicates that although a single suitport saves approximately 73 kg *landed* mass versus the minimum functional tunnel, 119 kg of suitport mass also has to be launched with the MAV, requiring at least 800 kg of MAV propellant.

NASA flight rules generally require a “buddy system” (2 crew minimum) during EVA, so a single suitport would violate this protocol for the final crew member to ingress the MAV. Adding a second suitport to the MAV would be about 46 kg more landed mass than the minimum functional tunnel, and would require more than 1.6 metric tons of additional MAV propellant.

At nearly one meter centerline-to-centerline spacing between suitports, a small MAV cabin diameter is unlikely to provide sufficient real estate for more than two suit ports. This poses operational timeline impacts in getting more than two crew members in or out of the vehicle. Crews could ingress two at a time, but once the first two are inside, their suits would have to be removed from the suitports before the next two crew members could ingress. Once detached from the suit port, an empty suit can be damaged if the water inside freezes, which means additional thermal conditioning mass will be needed outside the vehicle for suit stowage—exacerbating what is already a poor mass trade for the suit ports. Worse, to protect against a contingency where the MAV engines fail to ignite and crew need to retreat back to a habitable element, the MAV may have to keep one or two EVA suits attached to its suitports until lift-off, further adding complexity and mass.

Because most of the tunnel mass remains on the surface, with no ascent mass penalty for the MAV, suitports simply do not trade as well as the minimum functional tunnel for MAV ingress.

Suitport-Airlock—One compromise solution is the Suitport-Airlock (Figure 16), sometimes referred to as a Suitlock. This provides the best of both worlds, but at considerably higher mass than either individual option. As compared to a reusable tunnel that is relocated after the MAV departs, the Suitport-Airlock may trade well, assuming that it can be

relocated as readily as a tunnel could.

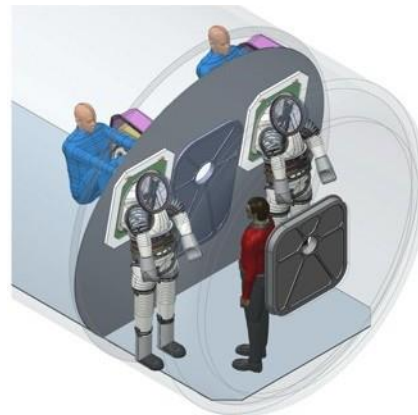

Figure 16. Suit Lock Concept

8. CONCLUSIONS

There are at least seven functional requirements that must be considered for a minimum functional tunnel that helps returning Mars crews comply with planetary protection protocols. The mass of a minimum functional tunnel for MAV ingress is estimated to be about 237 kg, not including mass growth allowance or a tunnel inflation system. Preliminary analysis indicates that an inflatable tunnel trades more favorably for mass than suitports in this application, but additional forward work is necessary to refine the concept and assess other alternatives.

Although not necessarily a practical solution, this “one job, one time” minimal functional baseline configuration will serve as a starting point from which to evaluate MAV ingress alternatives, or to measure the mass penalties as additional functionality is added.

ACKNOWLEDGEMENTS

The authors thank Alida Andrews, Steve Chappell, Steve Hoffman, Bret Drake, Kevin Watts, Marianne Bobskill, Brand Griffin, Chris Jones, Kara Latorella, Mark Lupisella, Michael Wright, Matt Simon, Leslie Alexander, and Mike Baysinger for vigorous technical discussion.

REFERENCES

- [1] Craig, D.A., P. Troutman, N.B. Hermann, AIAA 2015-4409, “Pioneering Space Through an Evolvable Mars Campaign,” AIAA Space 2015 Conference and Exposition, Pasadena, 2015.
- [2] Boyle, R. M.; et al., “Suitport Feasibility--Human Pressurized Space Suit Donning Tests with the Marman Clamp and Pneumatic Flipper Suitport Concepts,” AIAA 43rd International Conference on Environmental Systems, Vail, 2013.
- [3] NASA NPI 8020.7/NPD 8020.7G, “NASA Policy on

Planetary Protection Requirements for Human Extraterrestrial Missions,” National Aeronautics and Space Administration, Washington, 2014.

[4] Rucker, M.A., AIAA-2015-4416, “Mars Ascent Vehicle Design Considerations,” AIAA Space 2015 Conference and Exposition, Pasadena, 2015.

[5] MPCV 70024, Orion Multi-Purpose Crew Vehicle (MPCV) Program: Human-Systems Integration Requirements, National Aeronautics and Space Administration, Houston, 2015.

[6] de la Fuente, H., et al.; AIAA-2000-1822, “Transhab: NASA’s Large-Scale Inflatable Habitat,” AIAA Space Inflatables Forum; Structures, Structural Dynamics, and Materials Conference, Atlanta, 2000.

[7] Barido; et. al., “Breadboard Development of the Advanced Inflatable Airlock System for EVA,” 2003-01-2449, International Conference on Environmental Systems, Vancouver, 2003.

[8] Campbell; et al., “Advanced Inflatable Airlock System for EVA,” 2002-01-2314, 32nd International Conference on Environmental Systems, San Antonio, 2002.

[9] Thompson, S. and M. Rucker, “Surface Vehicle Task 516: Two and Three Crew Mockup Configuration and Comparison Evaluation Final Report,” National Aeronautics and Space Administration, Lyndon B. Johnson Space Center, Houston, 2011.

[10] TP-2006-213726, “The Apollo Experience Lessons Learned for Constellation Lunar Dust Management,” National Aeronautics and Space Administration, Lyndon B. Johnson Space Center, Houston, 2006.

BIOGRAPHY



Michelle Rucker received a B.S. (1984) and M.A. (1986) in Mechanical Engineering from Rice University and has been with NASA for 29 years. She currently serves in the Exploration Integration and Science Directorate at the Johnson Space Center. She began

her NASA career as a test engineer at the White Sands Test Facility before moving onto roles as a deputy subsystem manager for the International Space Station, EVA and Spacesuit Systems Deputy Branch Chief, and Altair Lunar Lander Test and Verification Lead.



A. Scott Howe is a licensed architect and robotics engineer at NASA’s Jet Propulsion Laboratory. He earned PhDs in industrial and manufacturing systems engineering from Hong Kong University and in architecture from University of Michigan. Dr. Howe spent 13 years of practice in Tokyo, Japan,

and taught for 6 years at Hong Kong University. He specializes in robotic construction and currently is on the NASA development team building long-duration human

habitats for deep space and permanent outposts for the moon and Mars. Dr. Howe is also a member of the JPL All-Terrain Hex-Limbed Extra-Terrestrial Explorer (ATHLETE) robotic mobility system development team, Asteroid Redirect Mission (ARM) capture mechanism team, and Mars Sample Return (MSR) Orbiter design team.

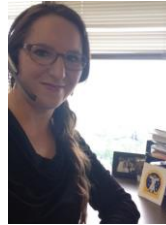

Natalie Mary is experienced in human space flight as an accomplished International Space Station (ISS) flight controller at NASA Johnson Space Center (JSC) and is a lead system’s engineer in the Exploration Integration and Science Directorate Extra-vehicular Activity (EVA) Office. Natalie is currently providing support as a Booz Allen Hamilton associate to the EVA team for development of the NASA exploration space suit. Natalie’s focus is on system’s engineering such as requirements, architecture, interfaces, and operational concepts for multiple missions, including the ISS and future exploration space suit capabilities for the journey to Mars. Natalie received a B.S. in Aerospace Engineering from Texas A&M University and is an INCOSE Certified Systems Engineering Professional (CSEP).

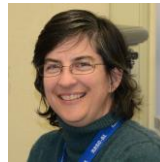

Sharon Jefferies is an aerospace engineer in the Space Mission Analysis Branch at NASA Langley Research Center. She has been at NASA since 2006 and has supported systems concept and mission designs for lunar, NEA, and Mars mission studies under the Human spaceflight Architecture Team (HAT) and for NASA’s Asteroid Redirect Mission. Her background is in crew mobility and robotic systems concept development, mission concept-of-operations development, and capability needs assessment. Ms. Jefferies is currently leading the integration of systems across the Evolvable Mars Campaign and is supporting system concept development. Ms. Jefferies has a Bachelor of Science in Mechanical Engineering from the United States Military Academy.



Judith Watson is a senior structures research engineer at NASA Langley Research Center. For the majority of her career she has specialized in the development and evaluation of innovative concepts for the assembly or deployment of very large spacecraft structures for science and exploration missions. She is currently a member of the Minimalistic Advanced Softgoods Hatch (MASH) project, which is focused on technology for inflatable airlocks and habitat structures. Ms. Watson has a B.S. in Aerospace Engineering from the University of Alabama and a M.S in Engineering Mechanics from Old Dominion University.



Robert Howard is Dr. Robert Howard is the lab manager for NASA's Habitability Design Center at Johnson Space Center in Houston, TX. He leads a team of architects, industrial designers, engineers and usability experts to develop and evaluate concepts for spacecraft cabin and cockpit configurations. He has served on design teams for several NASA spacecraft study teams including the Orion Multi-Purpose Crew Vehicle, Orion Capsule Parachute Assembly System, Altair Lunar Lander, Lunar Electric Rover / Multi-Mission Space Exploration Vehicle, Deep Space Habitat, Waypoint Spacecraft, Exploration Augmentation Module, Asteroid Retrieval Utilization Mission, Mars Ascent Vehicle, as well as Mars surface and Phobos mission studies. Dr. Howard has a Bachelor of Science in General Science from Morehouse College and a Bachelor of Aerospace Engineering from Georgia Tech. He holds a Master of Science in Industrial Engineering with a focus in Human Factors from North Carolina A&T State University and a Ph.D. in Aerospace Engineering with a focus in Spacecraft Engineering from the University of Tennessee Space Institute. He also holds a certificate in Human Systems Integration from the Naval Postgraduate School and is a graduate of the NASA Space Systems Engineering Development Program.



Ruthan Lewis is the Exploration Systems and Habitation Manager at NASA Goddard Space Flight Center leading formulation, development, and design of human Mars, lunar, and deep space exploration systems. She has served at three different NASA centers performing research in human ergonomics and space environment interaction, coordinating science and engineering integration systems and habitation design, and conducting inflight operations with roles including but not limited to Space Shuttle Mission Manager, ISS Research Manager, and Hubble Space Telescope EVA Systems Manager. Dr. Lewis received her Ph.D. in Industrial and Biomechanical Engineering from Texas A&M University, an M.S. in Architecture from Catholic University, an M.S. in Industrial and Biomechanical Engineering from Texas Tech University, and a B.S. in Architecture and a B.S. in Biomechanics from the University of Maryland.